

Die Holders

Specifications

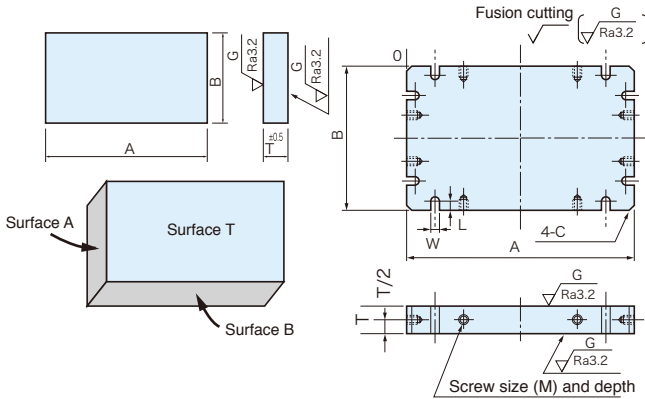

We can also perform hollow fusion cutting, U-channel, and hanger bolt type machining.

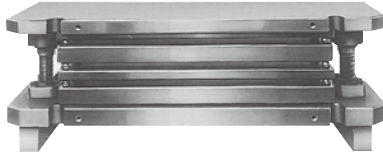
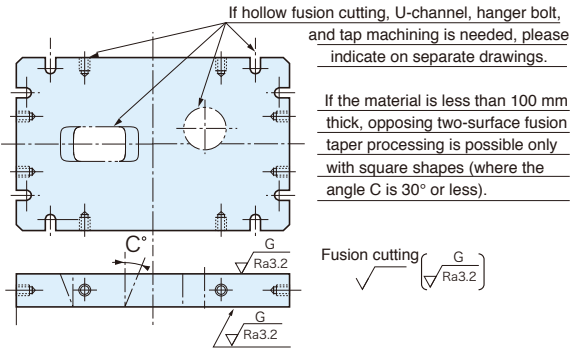

※All machining is subject to quotation.

